

# Tutorial: Top Balancing LiFePO4 Cells using a low cost 10A benchtop power supply.

**Disclaimer:** There are a lot of opinions about how to properly top balance LiFePO4 cells. Some of the debates get almost religious in the fervor. I do not profess to be the final word on this, but I am willing to share what works for me. If you can use this tutorial or even parts of this tutorial, great. If you totally disagree, that is fine as well.

**NOTE:** In the following, I show how to top balance to 3.65 volts. This is an aggressive top balance. Many people top balance to 3.6 volts or lower. If you decide to use a different voltage, adjust the voltages accordingly. (See more on this in Section 2 of this paper.

**Warning:** This procedure involves assembling and disassembling the cells into different configurations: Be very careful of the threads in the cell terminals. Taking stainless steel studs in and out will damage the aluminum threads. I advise putting the studs into the cell terminals once with red Loctite and never taking them out again.

## 1 Power Supply:

For top balancing, I use this 10 Amp power supply:

<https://www.amazon.com/gp/product/B07ML2MP9Q>

There are several similar supplies available in this price range. The key is to have both Constant Voltage and Constant Current controls for your supply. @Will Prowse recommends a similar one on his tools page:

<https://www.mobile-solarpower.com/tools.html>

Note 1: The above power supplies will work for top-balancing any LiFePO4 Cell, but will only work for 24V and 12V Pre-charging (See below about pre-charging). If you need to pre-charge 48V banks, a 60V supply is recommended.

Note 2: 10A supplies tend to be the sweet spot for pricing. Higher amp supplies will allow you to top balance faster but they tend to be a lot more expensive.

Note 3: The leads that come with these supplies are not particularly good. They tend to be high enough resistance that you can get a large enough voltage drop when driving 10 Amps that it will slow down the process. The factory leads will work fine and achieve the same result, but it is advisable to build your own heavy duty leads in order to speed up the process. Using a larger wire size is good, but the most important 'upgrade' for the leads are the end connectors. The best leads for this purpose will have properly sized ring connectors on both ends. (Not banana plugs and alligator clips) (See Appendix D)

## 2 When to top balance.

Top balancing is typically done when your cells are going to be assembled into a battery with a BMS for solar systems. In this case, the BMS will typically be top balancing the cells so any other type of cell balancing will quickly be defeated. Furthermore, the batteries will spend very little of their life at the bottom levels of charge so balancing them at the top will be most effective.

Quite often, new and matched cells will be delivered 'balanced'. Unfortunately, I do not know of a way to determine that they are balanced other than to build the battery and do a capacity test. If you assemble the pack and find it meets the Ah rating expected, there is little need to do an additional top balance.



Once you top balance the first time, you will not typically need to top balance again, particularly if you are starting with reasonably matched cells. The cells will tend to age similarly to each other and the BMS balancing will tend to keep them top balanced. The exception to this is if you are charging and discharging at very high C rates. In these conditions, the differences between the cells can be amplified and the BMS may not be able to keep up. (This is not typical for solar installations).

### **3 Pre-charging the cells to get them 'mostly' charged.**

If your cells are mostly charged, you can skip this section and go to next section: "**4 Top Balancing your cells**".

If your cells are not mostly charged, trying to top balance them in parallel with a 10A supply means you are only charging at  $\sim 3.4V \times 10A = 34$  watts. This could take an exceptionally long time, possibly days. To speed up the process, I charge them in series with a BMS first:

1. Assemble the cells in series and add your BMS to create a full battery.
2. Set the BMS to shut off charge when any cell reaches 3.65V. (3.6V for 3.6v top balance)
3. Set the power supply constant current to .2 C or less.
  - 3.1. While the power supply is disconnected from the batteries and turned off, short the leads together.
  - 3.2. While the power supply is off, Set the voltage arbitrarily high and the current as low as it will go.
  - 3.3. Turn on the power supply and slowly turn up the current till you hit the target current.
  - 3.4. Disconnect the leads

Note: For most cells used in solar systems, .2 C is a lot more than 10 Amps. (.2C of 100Ah cells is 20A). Consequently, in most cases you can just max out the current setting on the supply.

4. With the power supply disconnected, set the voltage to your target pack voltage.

For a 12 V system:  $3.65 \times 4 = 14.6$  Volts. (or 14.4 V for 3.6v top balance)

For a 24 V system:  $3.65 \times 8 = 29.2$  Volts. (or 28.8 V for 3.6v top balance)

For a 48 V system:  $3.65 \times 16 = 58.4V$ . (or 57.6V for 3.6V top balance)

Hook the power supply to the + and – of the battery. (Be sure to get the polarity correct or you will get a very large spark and possibly damage the power supply... don't ask how I know this.)

5. Let the battery charge till the BMS does an over-voltage disconnect. Depending on the Cell size and SOC, this could take several hours.
6. Once the BMS shuts off charge, turn off the power supply and disassemble the battery. At this point your cells are mostly charged but they are **not balanced**.

**Note 1:** This pre-charging step assumes your cells all start out at a similar state of charge. However, if one of the cells starts out at a considerably higher SOC, it will hit 3.65V and stop the process before the other cells get mostly charged. This does not hurt anything, but the top balancing process in the next section will take a lot longer. If you suspect your cells have are starting with significant differences in SOC, you can put them in parallel overnight to let them equalize before you start the pre-charge. (I do not find this necessary with new cells.)

**Note 2:** The low-cost Power Supply referenced above will not reach the required voltage for pre-charging a 48V bank. However, the power supply for this step can be any supply that will achieve the required voltage. I will often use an Inverter/Charger or an AC charger for this step.

## 4 Top Balancing your cells

**Note 1:** The following procedure is essentially the same as what Will Prowse shows in his video: <https://diysolarforum.com/threads/top-balancing.8193/page-4#post-89059>

**Note 2:** The procedure below uses 3.65V as the target voltage for top balancing. Some people feel this is higher than necessary. One somewhat common target voltage that others use is 3.6V and I have heard a few even use as low as 3.5V. (I would not recommend anything lower than 3.5V). For best results, be sure to charge to a voltage that is above the max cell voltage your BMS will be set to during normal usage. This will help prevent one cell from suddenly going over-voltage when the cells are nearly charged.

1. Wire all your cells in parallel.

Note: If your cells are more than about .15V different, it is probably best to charge the lower cells to about the same as the higher cell(s) before paralleling them. To do this, parallel the lower voltage cells and use this top balance procedure to get them close to the voltage of the higher cells and then top balance them all)

2. Before hooking the power supply to the cells, set the power supply to .2C or less of the combined AH of the cells. This will almost always turn out to be the max current setting of the power supply.
3. Set the voltage on the power supply to 3.65V.
4. Hook the negative lead to the negative pole of one end of the series of cells and the positive lead to the positive pole at the other end of the series of cells as shown in the image on the right (Be sure to get the polarity correct). The diagonal hook-up helps balance the resistance between the power supply and the individual cells.
5. At this point the cells are all being charged to 3.65 volts. Depending on the SOC of the cells, your power supply might be current limited and the voltage on the display will be less than 3.65 volts. Do not adjust the voltage!

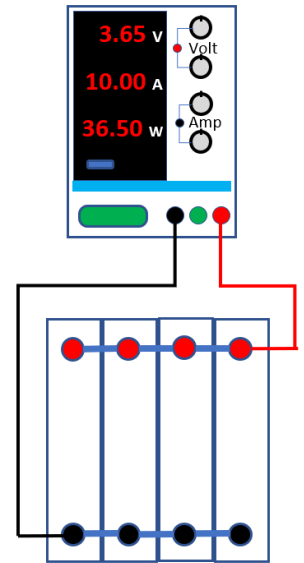

NOTE: You might notice that the voltage at the cells is lower than the voltage shown on the power supply. You might also notice that the voltages between individual cells are different. This is normal and is due to the resistance of the leads and interconnects. As the cells charge and the current starts to drop, you will see the voltage differences between the Cells and the power supply go to zero.

NOTE: **Be patient.** Depending on the state of charge when the top-balancing started, this can take a long time. Perhaps multiple days. It may sit at the same voltage and not change for a very long time. This is normal. Don't give up and don't try to increase the voltage to speed things up.

Because the voltage clamp on the low-cost power supplies often have a small drift (Typically ~0.02V) I do not leave cells unattended if the Power Supply is set at 3.65V. If I need to leave the cells unattended, I will set the PS to 3.6V or even 3.55V and let them top charge unattended. When I have time to 'babysit' the cells I will then re-do the balance at 3.65V. Since the cells are already top balanced to above 3.5V, the final top balance is very quick. (Even at 3.55V I do not leave them unattended for long periods. I don't want them to sit at even 3.55 volts and no current for more than over-night)

6. Once you see the voltage at the cells reach ~3.5 volts, the voltage will start going up much faster. At this point start watching the voltage at the power supply closely. I do not trust the constant voltage circuit on the power supply to hold the voltage exactly at 3.65V, so at the end of the charging I use my multimeter and adjust the power supply to make sure the voltage at the power supply does not go above 3.65V. Do not worry if the voltage at the cell is lower than the Power Supply...they will catch up. (I find that the cells take 1-4 hours to get

to 3.65 V with 200AH 24V banks. Higher capacity banks of cells will take longer)

7. Once the cell voltage starts rising, the current will start dropping. Keep the power supply voltage at 3.65 volts till the current is zero or near zero. This usually takes less than an hour after you see the cell voltage rising quickly.
8. Once the current is zero, the cells are top balanced. Disconnect the power supply, disassemble the bank of cells and reassemble them into your final battery.

Note: After you complete the top balance and disconnect the power supply, you will see the voltage on the cells drift down to a lower resting voltage. Furthermore, the resting voltage might be a few millivolts different between the cells. This is normal.

## **Appendix A: Other opinions**

This section is to acknowledge a few things that others might do differently. I would not say the other opinions are wrong, it is just that my experience drives me to different conclusions.

1. Target voltage.

When I top balance, I push the cells to 3.65V. However, when I am setting the voltages in my charge controller, the cell voltage target is closer to 3.5V. Some folks believe that it would be better for me to top balance at 3.5V to match my run-time target voltage. I find it works better to balance to the higher voltage.

2. Don't top balance at all.

Since most BMSs will work to top balance the cells, some folks feel the whole top-balance process is unnecessary. There is some truth to this, particularly if your BMS has an aggressive balancing algorithm and high balancing current. However, it is likely to take the BMS an extremely long time to balance the cells... **if ever.**

If you choose not to balance your cells, you must set your charge voltage low enough to prevent the BMS disconnecting due to a cell voltage getting too high. Otherwise the BMS will cut out before the charger does. Likewise, your loads must disconnect at a high enough voltage to prevent the BMS from disconnecting due to a Cell undervoltage.

Also, if you are going to do a capacity test on the battery you just built with your new cells, balancing first will give you a more accurate result.

3. One reviewer felt that letting the current go to zero while balancing the cells to 3.65 would damage the cells. The reviewer said:

*"Paragraphs 4.6 and 4.7 can result in cell damage. Cell charge termination is typically at around 0.05C depending on manufacturer. This method of charging is typical at a tiny fraction of C, thus the INSTANT the CELLS hit 3.65V, the cells are OVER charged due to the very low current. There is no reason to wait for the current to taper to zero."*

I agree that the current does not have to go all the way to zero and that you can stop the top balance at near-zero current. However, LiFePO4 can tolerate charges higher than 3.65 without damage, so letting them go to zero current will not damage the cells. Furthermore, the cells are not fully balanced till the current goes to zero. If someone is concerned about this, they can either stop the top balance before the cells get to zero current or Top Balance to 3.64V.

## **Appendix B: Step-and-Pause top balance.**

There is a slightly more involved 'stepwise' top-balancing process where the cells are balance charged to a lower voltage, let rest and then driven to a slightly higher voltage. This continues till the target top voltage is reached.

(This is essentially the same process discussed in section 4 but done in multiple steps.)

There is nothing wrong with the step-and-Pause approach and there is general agreement that both approaches achieve an acceptable result. The debate between the two approaches comes down small differences in the outcome.

Regardless of whether the 'step-and-pause' or 'single step' method is used, the top balance concept and goal is the same: Get the cells all to the same state of charge and the same voltage.

I personally use the single step approach but have no issues with the multi-step approach either.

The following is a brief outline of the step-and-pause process as described on the MarineHowTo site. (<https://marinehowto.com/lifepo4-batteries-on-boats/> )

Note that they use a different target top voltage. If you want to target 3.65V you can adjust the voltages below accordingly.

- 1- Wire the cells in parallel
- 2- Set the power supply to 3.400V and 80% or less of the rated amperage (80% to not burn it out)
- 3- Turn on power supply and charge cells to 3.400V
- 4- When current has dropped to 0.0A at 3.400V turn off the power supply & set it to 3.500V
- 5- Turn on power supply and charge cells to 3.500V
- 6- When current has dropped to 0.0A at 3.500V turn off the power supply & set to 3.600V
- 7- Allow current to drop to 0.0A (or very close) at 3.60V
- 8- Done, pack is balanced.

**WARNING:** Top each cell up to a similar SoC level, prior to wiring them in parallel

**WARNING:** Top balancing, even at 3.600VPC needs to be closely monitored. Like equalizing flooded batteries you simply do not want to leave them unattended at these voltages for long periods of time. Once the cells hit 3.600VPC you may need to adjust your power supply, very carefully, so it does not overshoot target top-balance voltage. Watch your DVM not the power supply display

## **Appendix C: Top Balance by charging individual cells.**

Some people like to top balance by charging each cell individually to the target balance voltage. The arguments for doing this is that it can be done without disassembling the battery (Less chance of stripping terminal threads). They also feel that doing it this way is safer (less likely to mess up and over charge, but I do not understand that argument.

I personally prefer to parallel top balance because I know for sure all the cells get charged to the exact same voltage.

## **Appendix D: Power Supply Lead for minimizing Voltage Drop.**

The leads that come with the low-cost supplies are adequate but not great. The factory leads will work, but they will slow down the process due to voltage drops across the leads and connections. Consequently, I built heavy duty leads to use for this procedure. Using a larger wire size is good, but the most important 'upgrade' for the leads are the end connectors. The best leads for this purpose will have properly sized ring connectors on both ends. (Not banana plugs and allegator clips)

This is one of the leads I built for top balance work with the low-cost Power Supply. I used 8AWG stranded wire because that is what I had on hand. If I had 10AWG stranded or even 12AWG stranded on hand I would have used that instead.

Also note that for power supply leads, flexibility makes them much easier to use. Stranded wire from the hardware store is OK, but I like using high-strand Marine cable or welding cable because of it's flexibility.

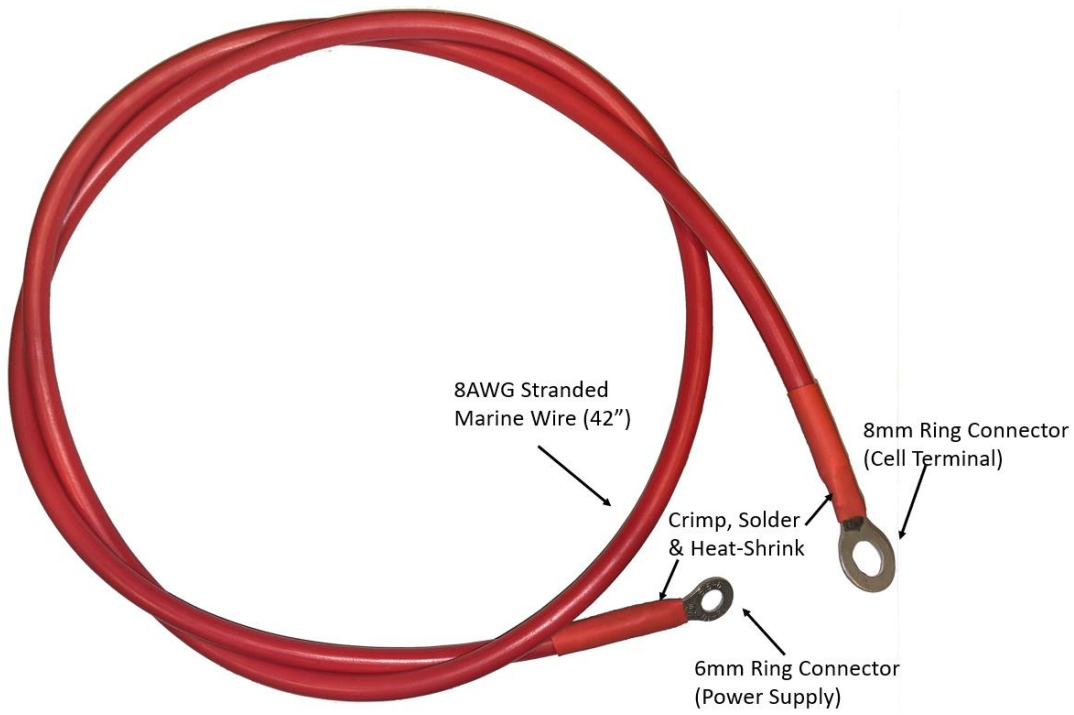

Note: I have cells with both 8mm and 6mm studs so I built it with an 8mm connector for connecting to the cells. This will work for 6mm studs, but if you are only doing cells with 6mm studs, a 6mm connector for the cell terminal would be better.

## **Appendix E: Edits from original version.**

**(Most recent change listed first)**

- Throughout: Minor formatting and typo updates.
- Section 4: Added Link to @Will Prowse's top balance Video
- Section 3: Added and then updated note about starting with cells that have significantly different SOC.
- Section 5: Added the "Other Opinions" section.
- Section 4: Added note about voltage drift after top balancing.
- Section 1: Added link to @Will Prowse's tools page for his power supply recommendation.
- Section 5: Added reviewers concern about letting the current go to zero at the end of top balancing.
- Added appendix that notes some people top balance by charging individual cells.
- Section 2: Added comment that if you assemble new cells and a capacity test indicates full capacity, the cells probably came balanced and further balancing may not be necessary.
- Section 3: Added note about getting cells close in voltage before putting them in parallel.
- Appendix D: Added appendix about DIY power supply leads.
- Section 4: Added image and text about hooking up the power supply to diagonal posts on the cells.
- Introduction: Added warning to be careful of cell terminal threads.
- 5/29/21 - Appendix D: Added comments about wire size and type.
- 5/29/21 - Section 4: Added note about target top-balance voltages.
- 5/29/21 - Section 1: Added note about Power Supply Amps
- 5/29/21 - Section 1: Added note that a higher voltage supply would be needed for pre-charging cells for 48V systems.
- 5/30/21 - Section 4: Added note about being patient with the process and about leaving the cells unattended.
- 5/30/21 – Section 3: Added note about power supplies for pre-charging.